

# BST CENON SAFETY KNIFE

METAL DETECTABLE, DISPOSABLE SAFETY KNIFE

PAGE 1 of 2

## Product Specifications

KN971400MB | Revised February 2015



**Product Name:** Cenon

**Product Description:** The CENON disposable metal detectable safety knife features a concealed blade designed to cut shrink wrap and plastic strapping (at a 45° angle), along with rear non-sharp pin for cutting packaging tape. The CENON is shaped to fit snugly into the hand, with minimal risk of injury due to the concealed blade.

The body of the knife is manufactured from food safe metal detectable polypropylene. The blade and tape cutter are both made from stainless steel, making the whole of the product fully metal detectable and food safe. The knife is compliant with standard No 1935/2004 (CE) of 27<sup>th</sup> October 2004 on materials and articles intended to come into contact with food.

**Product Prefix:** KN971400MB

**Product Colour:** Blue

**Pack Size:** Pack of 5

**Pack Weight:** 250g

**Product Advantages:**

- ✓ Detectable by conventional metal detection systems
- ✓ Highly visible blue colours for easy visual identification
- ✓ EU Food Contact Approved
- ✓ Effective for shrink wrap, plastic strapping and packaging tape
- ✓ Ambidextrous ergonomic design to prevent operator fatigue
- ✓ Highly robust construction with light but strong materials

### Product Material(s):

| Unit Weight | Unit Size (mm) | Order Quantity   | Parts per Unit | Parts       | Part Material                   | Part Colour(s) |
|-------------|----------------|------------------|----------------|-------------|---------------------------------|----------------|
| 46g         | 240 x 120 x 11 | Individual Knife | 3 Parts        | Shell       | Polypropylene (PP)              | Blue           |
|             |                |                  |                | Blade       | Food Processing Stainless Steel | Metallic Grey  |
|             |                |                  |                | Tape Cutter | Stainless Steel                 | Metallic Grey  |



# BST CENON SAFETY KNIFE

METAL DETECTABLE, DISPOSABLE SAFETY KNIFE

PAGE 2 of 2

## Technical Drawings

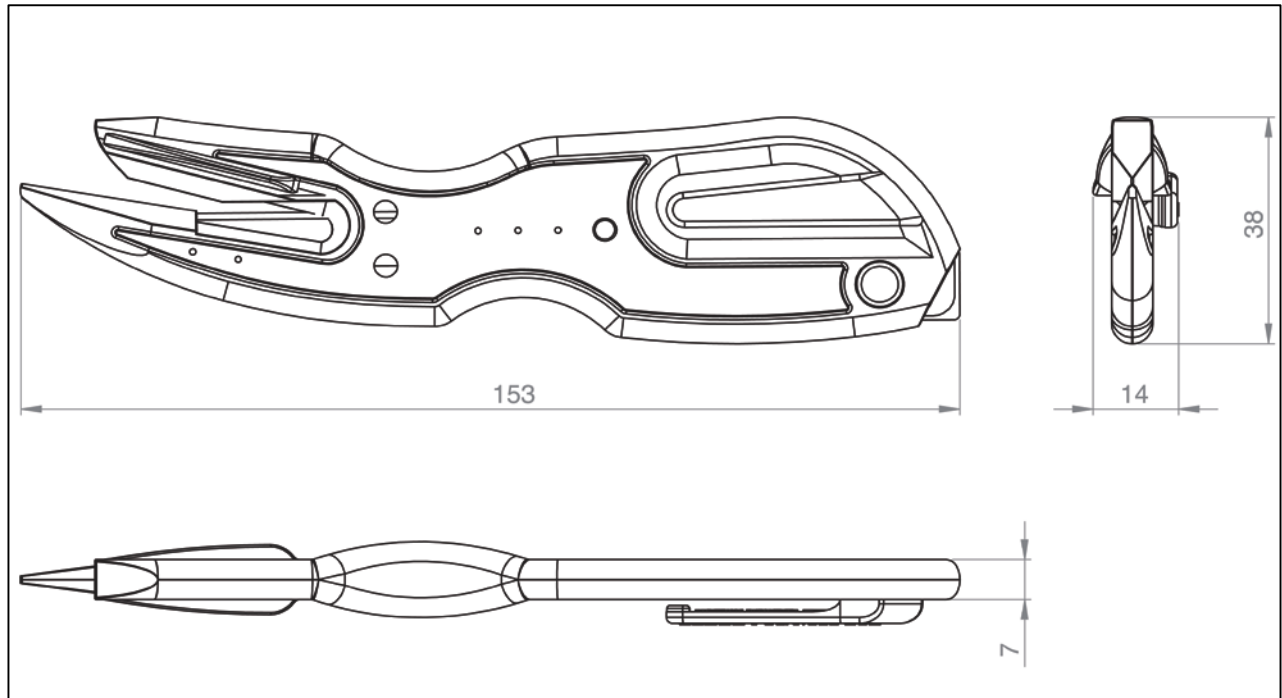

## Metal Detectability

The body of this safety knife is manufactured using plastic composite materials containing an evenly dispersed metal detectable additive. The detectability of these materials will vary based upon the metal detection systems being used and their calibration. All components of this safety knife are manufactured from metal detectable polymers or stainless steel, making the product fully metal detectable. Detectability performance will vary based on, but not limited to the following factors:

- Detector Calibration Levels
- Food Product Type (E.g. Wet, Dry, Frozen, Liquid)
- Aperture Dimensions
- Contaminant Orientation

For this reason BST recommend that all our products be thoroughly tested on your metal detection systems by a trained and certified professional. It may be the case that your equipment needs to be recalibrated in order to reliably detect this product and its fragments. Such a professional should be available by contacting the manufacturer of your metal detection system.

---

## DISCLAIMER

The information provided in this product specification sheet is based on our experience and knowledge to date and we believe it to be true and reliable. This information is intended as a guide for your use of our products, the use of which is entirely at your own discretion and risk. We, BS Teasdale & Son Ltd, cannot guarantee favourable results and assume no liability in connection with the use of our products.

© 2014 BS Teasdale & Son Ltd. All Content, Data & Images are owned by BS Teasdale & Son Ltd and are protected by international copyright law.

